

SITES GLASS-LINED INDUSTRIAL SOLAR/ELECTRIC WATER HEATER

SITES - 1000/1500/2000/2500/3000



- Electric water heater for high hot water demand requirements
- Steel glass lined tank with glass lining for corrosion protection
- Maximum working pressure 7 bar
- Manhole 400mm
- T&P relief valve factory supplied
- Factory installed 100 mm insulation with ABS jacket, meeting new Ecodesign standards in Europe
- Electric back-up heating with incoloy sheathed elements (15 to 60 kW)
- Factory mounted heating package with control panel including main power disconnect door interlock switch, transformer for 230 Volt control circuit, contactors, solar control panel, step indication lights and override switch, immersion control and hi-limit thermostat



SAMPLE SPECIFICATION

The heater(s) shall be STATE SITES series Commercial Electric water heater Model Number SITES_(1000/1500/2000/2500/3000)___ or an approved equal. Heater(s) shall be rated at _(15/30/45/60)_ KW, 400 V, 3 phase, 50/60 cycle AC. The heater shall be for (vertical/ horizontal). Vessel shall be constructed to European Pressure Directive for 7 bar working pressure. Vessel shall be glass-lined with anodic protection. Entire vessel shall be insulated with 100mm insulation with ABS cladding. The electrical and solar controls will be mounted on the heater in an IP 55 control cabinet. A combined temperature and pressure gage will be on the front of the heater. The heater will have a build in solar fluid heat exchanger suitable for up to 50 solar collectors. The solar fluid circulating pump will be controlled by the heaters control panel via a thermally protected switch relay. There shall be ___(1 or 2)___ individually replaceable ___(15 or 30)___ kW, flange mounted, incoloy sheathed heating elements each complete with prewired terminal leads for electric back-up heating. These elements will be switched by magnetic contactors which are operated by a 230V fused control circuit protected by manual reset high limit. Control circuit is activated by a master pilot switch. Each element will have an override switch for manual de-activation. The controller shall make maximum use of solar heating and switch on back-up only if solar heat does not satisfy hot water demand. The control of the contactors shall be in ___(1or 2)___ stages through thermostatic step control. This control shall fully automatically maintain the set temperature via solar heating and/or electric back-up. It shall prevent the entire electrical load from being switched on instantaneously. The entire water heating package shall be prewired to solderless terminal lugs, factory tested, complete with ASME temperature and pressure relief valve and bear the CE label for the electric components. Heater(s) shall have a 3 year limited warranty as outlined in the written warranty. Fully illustrated instruction manual included.

		SITES 1000	SITES 1500	SITES 2000	SITES 2500	SITES 3000
General						
Volume	litres	1000	1550	1820	2550	2820
Empty weight	kg	315	434	456	604	632
Max. floor load	kg	1315	1984	2276	3154	3452
Shipping weight	kg	355	474	496	644	672
Stand by heat Loss	kW/24 hr	3,0	3,7	4,1	5,6	5,8
Max. operating pressure tank	kPa (bar)	700(7)				
Test pressure tank	kPa (bar)	1100(11)				
Max. operating pressure heat exchanger	kPa (bar)	600 (6)				
Test pressure heat exchanger	kPa (bar)	1200 (12)				
Max. water temperature tank	°C	85				
Max. water temperature heat exchanger	°C	110				
Anodes	-	3				
Capacity heat exchanger	kW	135	136	136	144	144
Primary flow 80/60°C	l/h	6.235	6.485	6.485	6.871	6.871
Pressure loss	mbar	259	830	830	695	695
Heat exchange surface	m2	5,13	5,2	5,2	5,5	5,5
Maximum number of solar collectors	-	50	50	50	50	50

BACK-UP HEATING | SITES

heating capacity in kW	recovery capacity in liters per hour	
	15-40°C	15-60°C
15	516	287
30	1.032	573
45	1.548	860
60	2.064	1.147

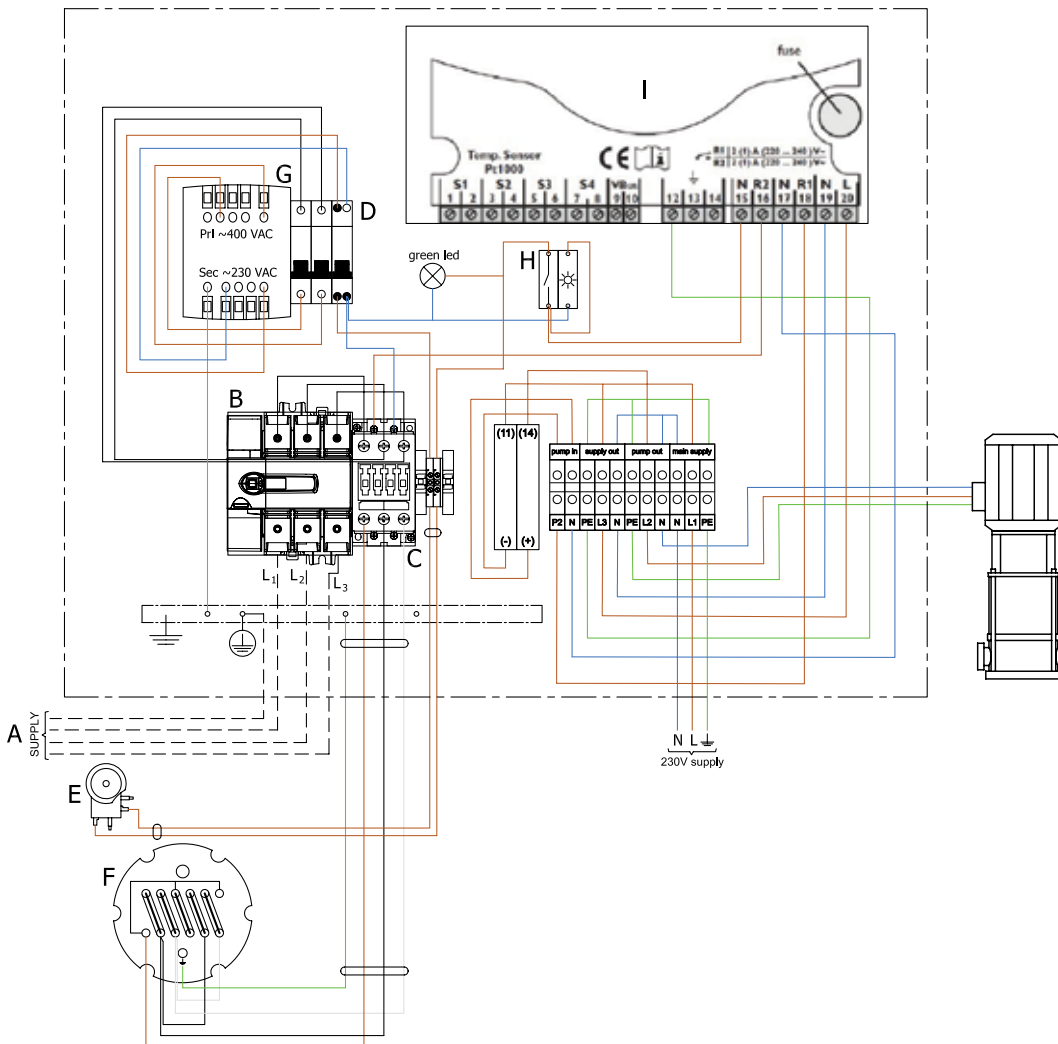

TERMINAL BLOCK CONNECTIONS

- ⊥ Earth
- N Neutral
- L1 Fase-input
- L2 Fase-input
- L3 Fase-input

COMPONENTS

- A Power supply
- B Main power disconnect switch door interlock
- C Relay
- D Automatic fuse
- E Combined control/safety thermostat
- F Electrical heating element
- G Transformer 400VAC/230VAC
- H Manual override switch and indication light
- I Solar control

- 1 Pressure reducing valve (mandatory if the mains water pressure is too high)
- 2 Inlet security group combining 8 bar pressure relief valve (15) and check valve (5) (mandatory)
- 3 T&P valve (mandatory - factory delivered)
- 4 Stop valve (recommended)
- 5 Non-return valve (mandatory)
- 6 Circulation pump (optional)
- 9 Drain valve
- 11 Stop valve (recommended)
- 12 Temperature gauge (recommended)
- 15 Pressure relief valve
- 16 Expansion vessel (recommended)

- A Cold water supply
 B Hot water outlet
 C Circulation pipe
 F Solar fluid in
 G Solar fluid out
 S Tank temperatures sensor openings

In the instruction manual you will find all the necessary information regarding connection, installation and maintenance of the product; including information on the electrical connections.

Information regarding the recycling or disposal of the product can also be found in the manual. This manual is delivered with the appliance and can also be found on our website; www.statewaterheatersme.com

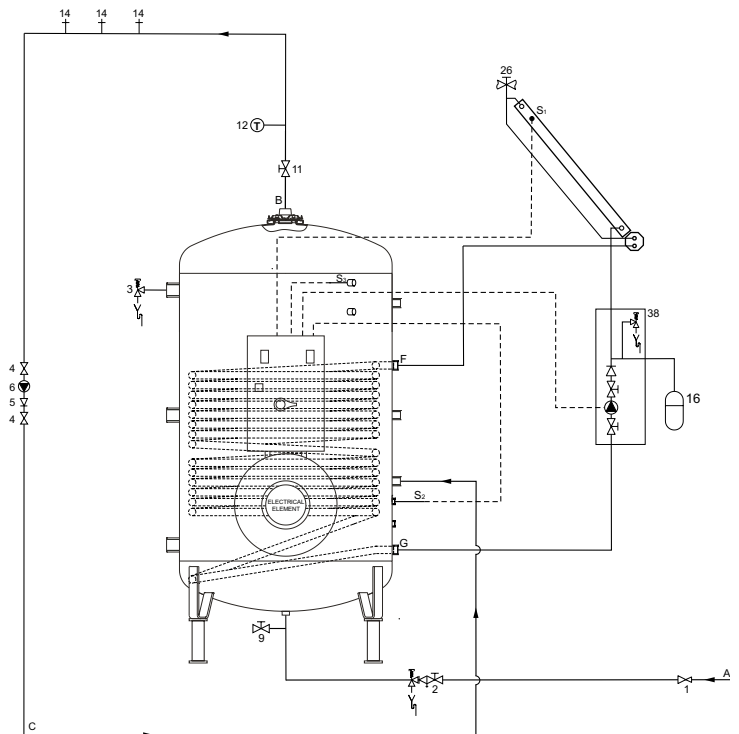

	SITES 1000	SITES 1500	SITES 2000	SITES 2500	SITES 3000
A	2160	1985	2170	2045	2170
D	790	1100	1100	1400	1400
	990	1300	1300	1600	1600
G	430	350	350	430	430
F	1280	1305	1305	1280	1280
M	170	220	220	220	220
N	2310	2185	2370	2245	2370
R	350	400	400	480	480
S	1075	950	1045	880	1045
T	1805	1500	1690	1380	1610
Z	150	200	200	200	200

1	Cold water inlet	Rp 2
2	Hot water outlet	Rp 2
3	Inlet heatexchanger	Rp 1 1/4"
4	Outlet heatexchanger	Rp 1 1/4"
8	Connection anode	Rp 3/4"
11	Connection/alt cold water inlet	Rp 2
12	Connection	Rp 2
14	Connection	Rp 2

All dimensions are in mm

