

SIT COMMERCIAL INDIRECT TANKS

SIT - 80/100/125/170/190/270/410/500/670/740



SIT range of commercial indirect storage tanks are suitable for installations with a variety of heat sources. The units are manufactured with heavy gauge steel and protected from corrosion by an advanced glass lining process. Storage capacities range from 300 up to 2800 litres with heating outputs from 46 - 142 kW.

- Single-wall spiral heat exchanger
- Glass lined steel tank
- Coil surface area (1.5 - 4.8 m²)
- Electrolytic protection - magnesium anode
- Removable 7 to 10 cm thick insulation with ABS cladding. The insulation will meet current strict European energy efficiency regulations
- Clean out inspection port
- Maximum tank working pressure 10 bar up to 1000 liter, 7 bar for 1500 to 2800 liter
- Tank operation temperatures up to 95°C
- Coil operation temperature up to 110°C
- Suitable for vented (open) or unvented (sealed) systems
- Optional accessories:
 - Temperature meter
 - Temperature & pressure relief valve
 - Electric heating elements up to 7.5 kW
 - Flexible magnesium anode
 - Powered anodes



SAMPLE SPECIFICATION

The tanks shall be State Water Heaters SIT series industrial Indirect hot water storage calorifier, model number _SIT_ xxxx (298-2800L) or an approved equal. The tank shall be for vertical installation. Vessel shall be constructed to European Pressure Directive for minimum 7 bar working pressure. Vessel shall be glass-lined, have 1 up to 3 sacrificial magnesium anodes for additional corrosion protection. Entire vessel shall be insulated with 70-100 MM insulation with ABS cladding. Heat loss will meet ErP standards. The tank will have the option to install a back-up electric element. A combined temperature and pressure relieve valve will be factory supplied. A factory installed boiler water/solar heat exchanger will meet the heating requirement.

		SIT 80	SIT 100	SIT 125	SIT 170	SIT 190	SIT 270	SIT 410	SIT 500	SIT 670	SIT 740	
General												
Output coil	kW	46	78	100	104	112	145	147	147	156	156	
Surface area coil	m ²	1.40	2.45	3.11	3.45	3.72	4.82	5.20	5.20	6.00	6.00	
Water capacity coil	l	8.8	14.8	18.8	29.3	31.6	40.9	40.0	40.0	45.0	45.0	
Flow rate coil (80-60°C)	l/h	1900	3354	4300	4472	4816	6235	6485	6485	6871	6871	
Pressure drop coil	mbar	80	244	489	104	128	259	830	830	695	695	
Maximum working pressure tank	kPa (bar)	1000(10)	1000 (10)					700 (7)				
Maximum working pressure coil	kPa (bar)	2500(25)	1600 (16)					600 (6)				
Maximum operating temperature tank	°C	95	95					85				
Maximum operating temperature coil	°C	160	110					90				
Storage capacity	l	296	385	473	643	725	1007	1550	1800	2550	2800	
Draw-off capacity T _{cold} = 10°C/T _{set} = 80°C												
30 min. ΔT=28°C	l	1236	1848	328	2723	2998	4018	5132	5632	7256	7756	
60 min. ΔT=28°C	l	1942	3046	3864	4321	4718	6245	7389	7889	9652	10152	
90 min. ΔT=28°C	l	2649	4244	5400	5918	6438	8472	9647	10147	12048	12548	
120 min. ΔT=28°C	l	3355	5442	6935	7515	8158	10699	11904	12404	14443	14943	
Continuous ΔT=28°C	l/h	1413	2396	3071	3194	3440	4454	4515	4515	4791	4791	
Heating-up time ΔT=28°C	min.	13	10	9	12	13	14	21	24	32	35	
30 min. ΔT=50°C	l	692	1035	1304	1525	1679	2250	2874	3154	4063	4343	
60 min. ΔT=50°C	l	1088	1706	2164	2420	2642	3497	4138	4418	5405	5685	
90 min. ΔT=50°C	l	1483	2377	3024	3314	3605	4744	5402	5682	6747	7027	
120 min. ΔT=50°C	l	1879	3047	384	4208	4569	5991	6666	6946	8088	8368	
Continuous ΔT=50°C	l/h	791	1342	1720	1789	1926	2494	2528	2528	2683	2683	
Heating-up time ΔT=50°C	min.	23	17	16	22	23	24	37	43	57	63	
30 min. ΔT=70°C	l	494	739	931	1089	1199	1607	2053	2253	2902	3102	
60 min. ΔT=70°C	l	777	1218	1546	1728	1887	2498	2956	3156	3861	4061	
90 min. ΔT=70°C	l	1059	1698	2160	2367	2575	3389	3859	4059	4819	5019	
120 min. ΔT=70°C	l	1342	2177	2774	3006	3263	4279	4762	4962	5777	5977	
Continuous ΔT=70°C	l/h	565	958	1229	1278	1376	1781	1806	1806	1917	1917	
Heating-up time ΔT=70°C	min.	32	24	23	30	32	34	51	60	80	88	
Shipping data												
Weight empty	kg	117	139	180	241	254	336	398	426	576	600	
Maximum weight	kg	413	524	653	884	979	1343	1948	2226	3126	3400	
Weight incl. packaging	kg	128	153	201	251	260	348	488	526	686	720	
Width packaging	mm	780	780	780	870	870	1010	1170	1170	1498	1498	
Height packaging	mm	1510	1850	2150	1930	2150	2100	2060	224	2120	2195	
Depth packaging	mm	780	780	780	870	870	1010	1426	1426	1680	1680	

	SIT 80	SIT 100	SIT 125	SIT 170	SIT 190	SIT 270
A	1650	1710	2045	1840	2035	2005
D	550	600	600	750	750	900
	750	740	760	910	930	1100
G	205	260	260	310	310	350
H	675	775	920	910	970	950
M	110	70	70	85	85	85
N	1460	1655	1995	1805	2000	1965
P	280	330	330	420	420	420
R	1050	860	1000	1000	1080	1040
S	495	500	500	655	655	705
T	1545	1365	1700	1480	1875	1605
U	-	-	-	-	-	-
Z	850	-	-	-	-	-

1	Cold water inlet	G 1"	R 2"	R 2"	R 2½"	R 2½"	R 2½"
2	Hot water outlet	G 1"	R 2"	R 2"	R 2½"	R 2½"	R 2½"
3	Heat exchanger outlet	G 1"	Rp 1"	Rp 1"	Rp 1¼"	Rp 1¼"	Rp 1¼"
4	Heat exchanger inlet	G 1"	Rp 1"	Rp 1"	Rp 1¼"	Rp 1¼"	Rp 1¼"
5	Circulation connection	Rp ¾"	Rp ¾"	Rp ¾"	Rp ¾"	Rp ¾"	Rp ¾"
6	Diameter inspection opening	110	115	115	180	180	180
7	T&P connection	Rp 1	Rp ¾"	Rp ¾"	Rp ¾"	Rp ¾"	Rp ¾"
8	Immerison well	Rp ¾"	Rp ¾"	Rp ¾"	Rp ¾"	Rp ¾"	Rp ¾"
9	Connection top tank temp. sensor	-	-	-	-	-	-
10	Anode connection	G 1¼"	Rp 1¼"	Rp 1¼"	Rp 1¼"	Rp 1¼"	Rp 1¼"
11	Connection electrical element	G 1 ½"	-	-	-	-	-

All dimensions are in mm

SIT 80

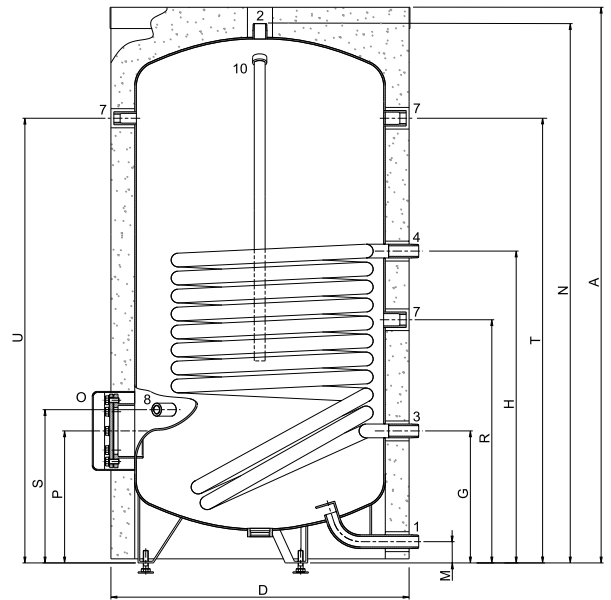

SIT 100 - 270

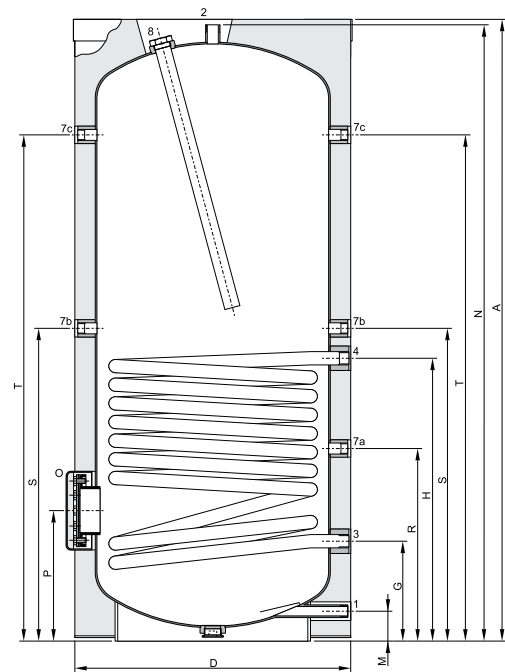

	SIT 410	SIT 500	SIT 670	SIT 740
A	1985	2175	2045	2070
D	1100	1100	1400	1400
	1300	1300	1600	1600
G	350	350	430	430
H	1305	1305	1285	1285
M	135	135	185	185
N	1985	2175	2045	2070
P	450	450	530	530
R	710	710	790	790
S	605	605	685	685
T	1515	1705	1530	1625
U	1550	1740	1530	1660
Z	-	-	-	-
S	605	605	685	685
T	710	710	790	790
U	1515	1703	1530	1624
V	1550	1738	1530	1659

1	Cold water inlet	R 2"	R 2"	R 2"	R 2"
2	Hot water outlet	R 2"	R 2"	R 2"	R 2"
3	Heat exchanger outlet	Rp 1 1/4"	Rp 1 1/4"	Rp 1 1/4"	Rp 1 1/4"
4	Heat exchanger inlet	Rp 1 1/4"	Rp 1 1/4"	Rp 1 1/4"	Rp 1 1/4"
5	Circulation connection	Rp 1 1/4"	Rp 1 1/4"	Rp 1 1/4"	Rp 1 1/4"
6	Diameter inspection opening	110	110	110	110
7	T&P connection	Rp 1"	Rp 1"	Rp 1"	Rp 1"
8	Immerison well	Rp 3/4"	Rp 3/4"	Rp 3/4"	Rp 3/4"
9	Connection top tank temp. sensor	Rp 3/4"	Rp 3/4"	Rp 3/4"	Rp 3/4"
10	Anode connection	Rp 3/4"	Rp 3/4"	Rp 3/4"	Rp 3/4"
11	Connection electrical element	-	-	-	-

All dimensions are in mm

SIT 400 - 740

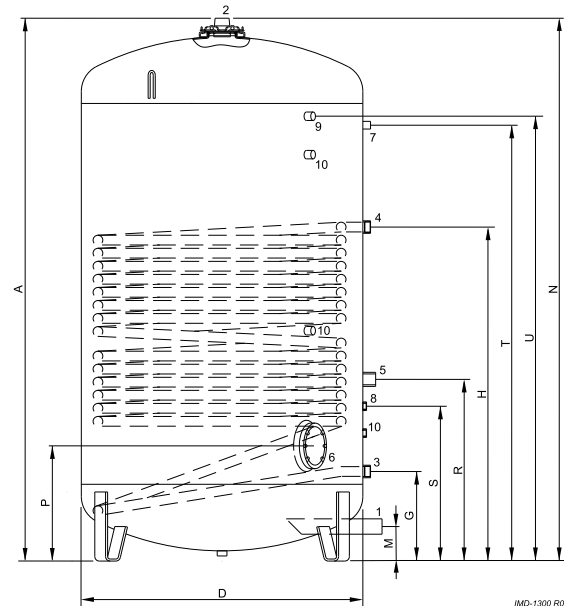

IMD-1300 R0

- 1 Pressure reducing valve
- 2 Inlet combination
- 3 T&P valve
- 4 Stop valve
- 5 Non-return valve
- 6 Circulation pump
- 9 Drain valve
- 11 Service valve
- 12 Temperature meter
- 14 Hot water tap

- A Cold water supply
- B Hot water outlet
- C Circulation pipe
- F Primary flow
- G Primary return

In the instruction manual you will find all the necessary information regarding connection, installation and maintenance of the product; including information on the electrical connections.

Information regarding the recycling or disposal of the product can also be found in the manual. This manual is delivered with the appliance and can also be found on our website; www.statewaterheatersme.com

SIT 80

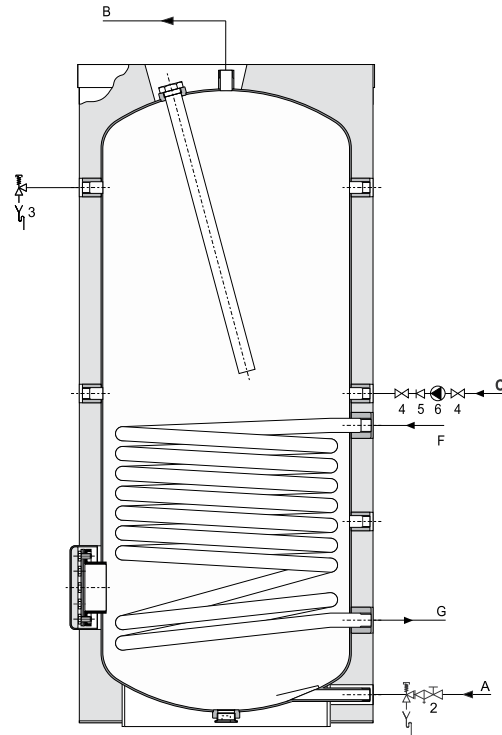

SIT 100 - 270

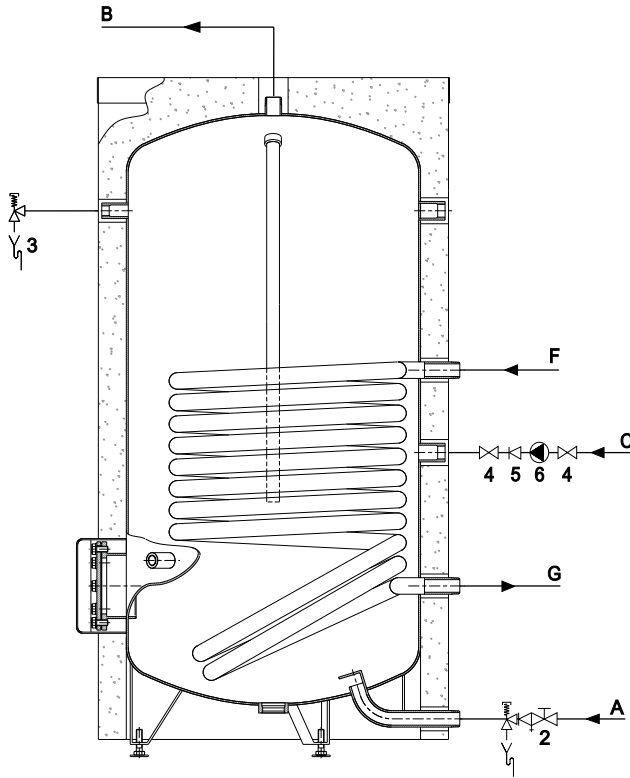

SIT 400 - 740

